

Model 504 Loading Valve

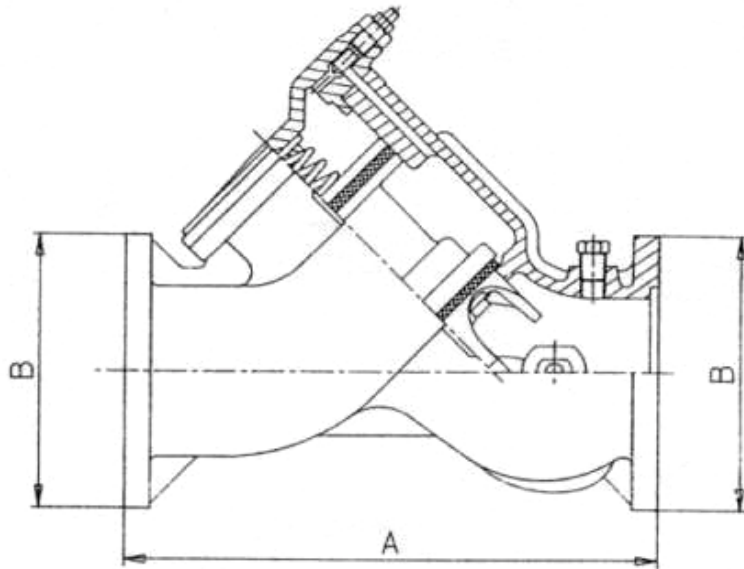

Dimensions / Weight

Size Inches	A (mm)	B (mm)	Weight (Kg)
3"	34 0	154	10.0
4"	37 2	190	15.0
6"	47 0	233	28.0

Body : Aluminium

Seals : Viton or Nitrile

Cam : Hold Open or Stay Open

Pressure Rating: 10.5 Bar

Viscosity: up to 600 Cst at 40° C

Model 504 Loading Valve

Used as standard on our range of 3", 4" & 6" Top Loading Arms.

Design includes a dual poppet to allow easy opening and shockless valve closure, valve closure time is externally adjustable to meet specific pressure and viscosity conditions, protecting inline pumps and meters.

Standard Loading Valve Options include

Stay Open Operation

The valves cam is locked in the open position until moved to the close position.

Hold Open Operation

The lever must be held in the open position by the operator during loading operations.

Loading Valve for Aviation Fuel

Fitted with Stainless Steel internal components, to replace brass components.

Product Information

Maintenance Manuals, Spare Parts Lists & Valve Closure Adjustments Instructions available by contacting EWFM or from our website.

Accessories

Vacuum Breaker – Model 2336 for 3" & 4" Loading Valves / Loading Arms.

Vacuum Breaker – Model 2361 for 6" Loading Valves / Loading Arms.

Valve Limit Switch – Model 2305 gives a closed contact under flow conditions.

EW Fuel Management Ltd

27 Kneesworth Street, Royston, Hertfordshire,
SG8 5AB. England.

Tel: + 44 (0) 1763 248 650 Fax: +44 (0) 1763 248 970

Email: sales@ewfm.co.uk

Website: www.ewfm.co.uk

EWFM Inc.

201 Wild Berry Lane, Harvest, AL,
35749 USA.

Tel : 256 417 4315 Fax : 256 417 4322

Email: sales@ewfuelmanagement.com

Website: www.ewfuelmanagement.com